

HIAS MOODLE+ RESOURCE

Science Vocabulary Year 6

**Word lists and classroom prompts to
support the vocabulary taught in the
Hampshire Science Learning Journeys**

Emma Cooper, General Inspector/Adviser for Science
June 2022
Final version

© Hampshire County Council

Overview

This document contains...

Classroom prompts to support the teaching of the key vocabulary in the Hampshire Science Learning Journeys.

Points to consider when using this resource

The words that children are exposed to within science can be split into two categories: the technical and non-technical. Technical words which are specific to a science subject or discipline: respiration and genes in biology; resistance and voltage in physics; mass and substance in chemistry. Non-technical words, when used in science, can have a meaning specific to the context in which it is being used. It is no wonder then, why children can find understanding of vocabulary within science challenging and sometimes confusing if a word they already know means a different thing within science.

It is therefore vital, that the language used within science lessons is appropriate. Vocabulary needs to be carefully considered and leaders should decide on how easy and accessible the meaning, of such vocabulary that will be shared with children, is.

Teacher will need to be mindful of how some words change their meaning within a science context and will need to carefully explain these words and their varied meanings.

This set of classroom prompts aim is to support children's understanding of the meaning of key words within the Learning Journeys.

Year 6 Key Vocabulary Lists

How Light Behaves

Shadow	A dark area or shape produced by a body or object coming between rays of light and a surface.
Opaque	Not able to be seen through.
Transparent	A material that allows light to pass through so objects behind can be clearly seen.
Translucent	A substance that allows light but not detailed shaped to pass through.
Reflection	The throwing back of light or sound without absorbing it.
Pupil	The pupil is the black circle in the centre. It opens and closes to control the amount of light that enters the eye.

Classification and Evolution

Evolution	The process by which different kinds of living organisms have developed from early forms over time.
Natural selection	The key mechanism of evolution where the best adapted organisms in a population are selected by nature to survive and pass on those physical features.
Population	All the members of a species that live in a one area.
Variation	The differences between the individuals in a species.
Competition	Species tend to produce more offspring than the environment can sustainably support leading to competition for survival.
Adapted	Modified features that make an organism more suitable for its purpose
Offspring	The young of living organisms, produced either by a single organism or, in the case of sexual reproduction, two organisms.
Inheritance	The passing on of characteristics to offspring.
Charles Darwin	Naturalist and scientist credited with the discovery of the mechanisms for how organisms adapt and change over time via the process of natural selection.
Lamarck	Jean-Baptise Lamarck was a naturalist who proposed an alternative mechanism for evolution centred around the inheritance of physical characteristics acquired during an organism's lifetime.
HMS Beagle	The Ship that Darwin sailed around the world on for 5 years and collected much of the evidence that led to his discovery of the process of Evolution by natural selection.

Controlling Electrical Circuits

Current	The flow of electricity through a conductor.
Voltage	The push on the electrical current through a conductor.
Volts	The unit for voltage.
Conductor	A material that will allow electricity to flow through it.
Resistance	A measurement of the opposition to electrical flow in a circuit.
Resistor	A component in a circuit that resists electrical flow.

Sound

Sound	Vibrations that travel through the air or other medium and can be heard when they reach an animal's ear.
Pitch	The rate or frequency of vibrations produced by a sound.
Volume	How loud or quiet a sound is.
Vibration	To move continuously and rapidly to and fro.
Ear drum	A membrane of the middle ear which vibrates in response to sound waves.
Frequency	How high or low a sound is determined by the rate at which vibrations occur over a particular period of time.
Amplitude	The maximum extent of a vibration.

Year 6 How light behaves

Shadow noun

Definition: a dark area or shape produced by a body or object coming between rays of light and a surface



Example: Trees cast long shadows.

Synonyms: silhouette, shade, outline.

Pupil noun

Definition: the black circle in the centre. It opens and closes to control the amount of light that enters the eye.



How it works: Muscles controlling the iris change the size of the **pupil** according to light conditions.

Opaque adjective

Definition: not able to be seen through

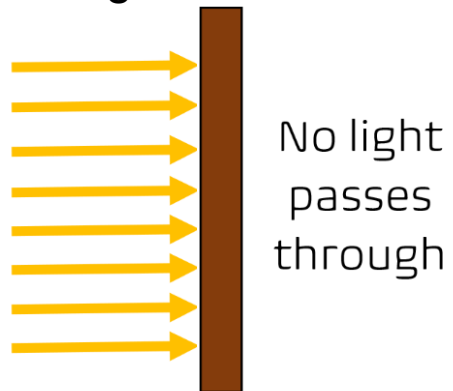

Example: The bottle was made of **opaque** glass so the contents could not be seen.

Synonyms: not transparent

Antonyms: transparent, translucent, clear

Transparent adjective

Definition: a material that allows light to pass through so objects behind can be clearly seen

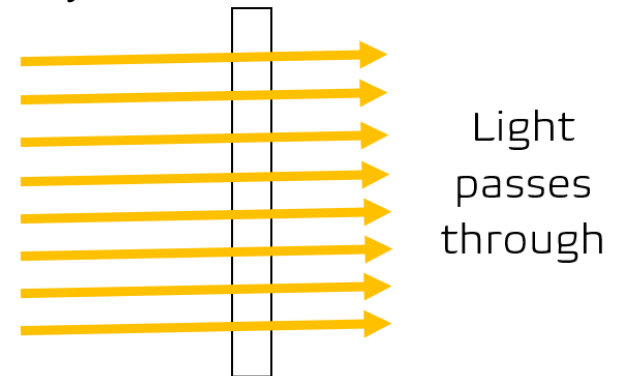

Example: from Latin *transparere*, from trans- 'through' + parere 'appear'.

Synonyms: see-through, clear, sheer

Translucent adjective

Definition: a substance that allows light but not detailed shaped to pass through

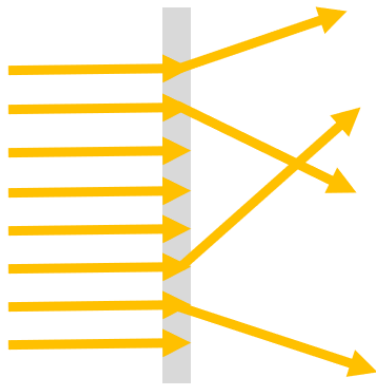

Some
light
passes
through

Translucent objects: sunglasses, frosted window, tracing paper, vegetable oil.

Synonyms- semi-transparent,

Reflection noun

Definition: the throwing back of light or sound without absorbing it

Synonym:
mirror image

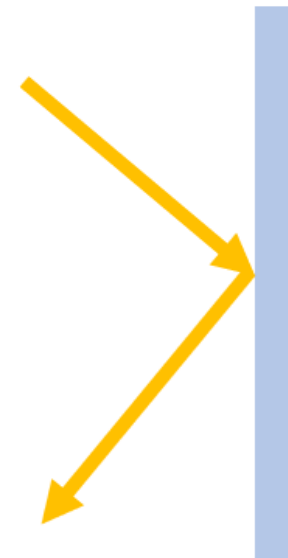

Reflective objects: foil, glass mirror, silver, snow, water, moon

Year 6 Classification and Evolution

Evolution noun

Definition: the process by which different kinds of living organisms have developed from early forms over time

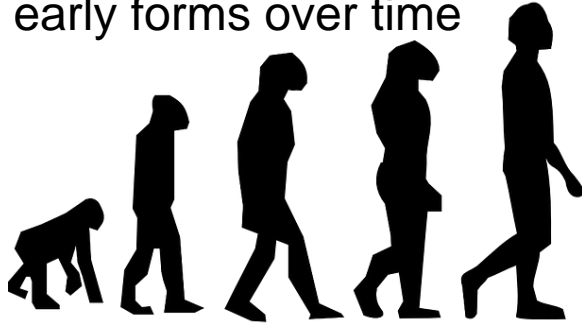

Example: Evolution is change happening over time.

Synonyms: Darwinism

Natural selection

noun

Definition: the key mechanism of evolution where the best adapted organisms in a population are selected by nature to survive and pass on those physical features

Example:
Natural selection shaped the evolution of humans.

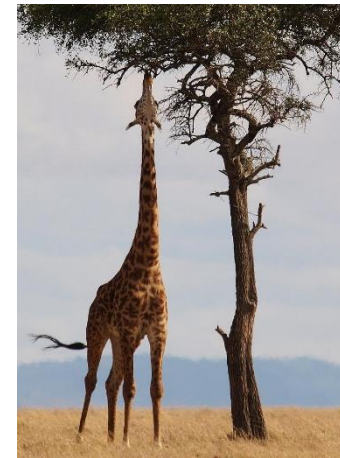

Population noun

Definition: all the members of a species that live in a one area



Example: When ecosystems become unbalance, whole **populations** of animals are more susceptible to diseases or other disturbances.

Word origin: from Latin *populus* meaning 'people'

Variation noun

Definition: the differences between the individuals in a species



Example: **Variation** helps a species to survive, by causing individuals of a species to be genetically and physically different.

Competition noun

Definition: interaction between species in which both require a resource that is in limited supply



Example: several species less suited for **competition** for the resources may either adapt or die out.

Offspring noun

Definition: the young of living organisms, produced either by a single organism or, in the case of sexual reproduction, two organisms.



Example: Human **offspring** are referred to as children.

Synonyms: young, babies, brood

Inheritance noun

Definition: the passing on of characteristics to offspring

Zedonk
(offspring of
a zebra and
a donkey)



Example: Animals **inherit** key characteristics from their parents, like eye colour, skin colour and height.

HMS Beagle noun

Definition: the Ship that Darwin sailed around the world on for 5 years and collected much of the evidence that led to his discovery of the process of evolution by natural selection

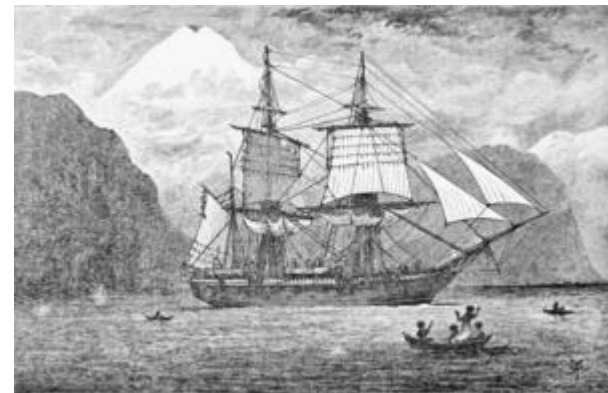

Charles Darwin

Charles Darwin (1809-1882) was a naturalist and scientist credited with the discovery of the mechanisms for how organisms adapt and change over time via the process of natural selection.

In 1831, Darwin accepted an offer to embark on a five-year voyage aboard HMS Beagle.

On his travels Darwin collected plants, animals and fossils, and took copious field notes.

On his return to England, in 1836, he spent many years comparing and analysing specimens before finally declaring that evolution occurs by a process of natural selection.

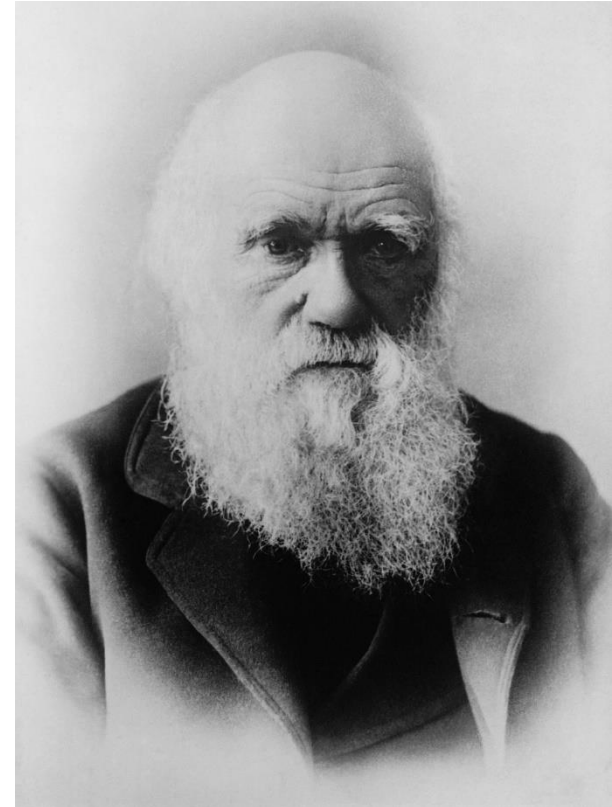

Lamarck



Jean-Baptiste Lamarck (1744-1829) was a naturalist who proposed an alternative mechanism for evolution centred around the inheritance of physical characteristics acquired during an organism's lifetime.

As an example, his idea as to why giraffes have long necks. He believed modern day giraffes have evolved from ancestors with much shorter necks. His idea was that adults needed to stretch their neck to reach leaves from high branches. Therefore, the children inherited longer necks.

Adapted adjective

Definition: modified features that make an organism more suitable for its purpose

Example: Desert animals like camels have adapted over thousands of years for life in an environment where there is little water available for long periods of time.

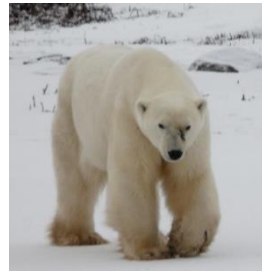

Synonyms: modified, altered, changed, adjusted

Adapt: verb

Year 6- Controlling Electrical Circuits

Current noun

Definition: the flow of electricity through a conductor

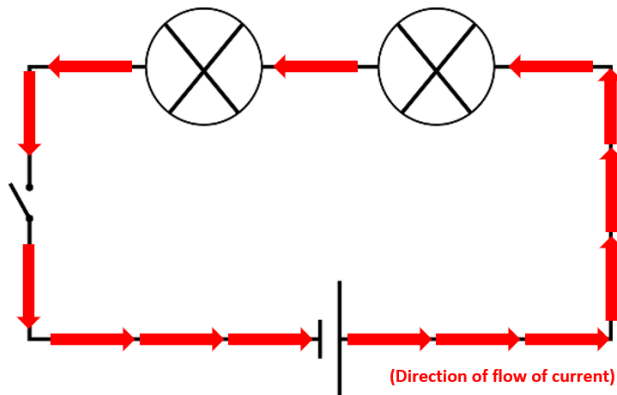

Example: A complete circuit is needed for the current to flow to the lamp.

Voltage noun

Definition: the push on the electrical current through a conductor

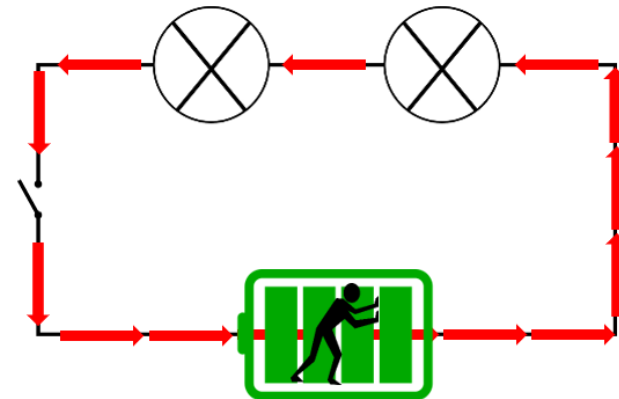

Example: Voltage can be measured using a voltmeter and is measured in volts.

Volts noun

Definition: the unit for voltage

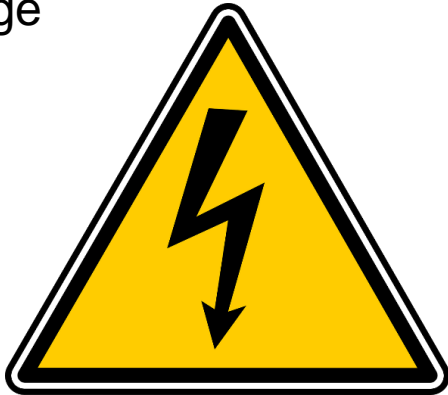

Italian physicist Alessandro Giuseppe Antonio Anastasio Volta (1745–1827). Volta is best known for the voltaic pile or electrochemical battery (1800), the first device to produce a continuous electric current.

Conductor noun

Definition: a material that will allow electricity to flow through it



Example: Most metals, like iron and copper, are electrical **conductors**.

Word origin: from Latin *conduct-* 'brought together'

Resistance noun

Definition: a measurement of the opposition to electrical flow in a circuit

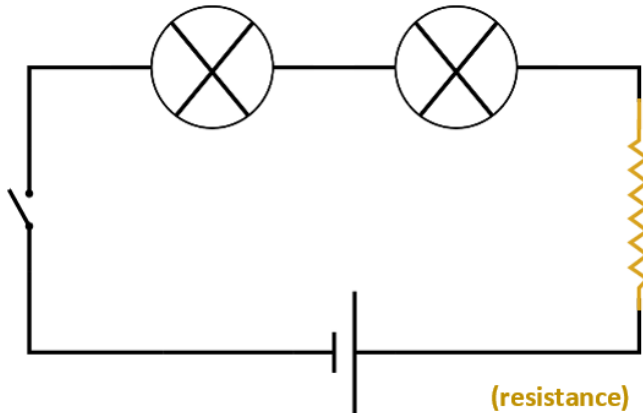

Example: The unit of **resistance** is the ohm , and it has the symbol Ω

Resistor noun

Definition: a component in a circuit that resists electrical flow



Example: The **resistor** also helps to reduce, or lessen, the amount of electricity moving through the circuit.

Year 6- Sound

Sound noun

Definition: vibrations that travel through the air or other medium and can be heard when they reach an animal's ear

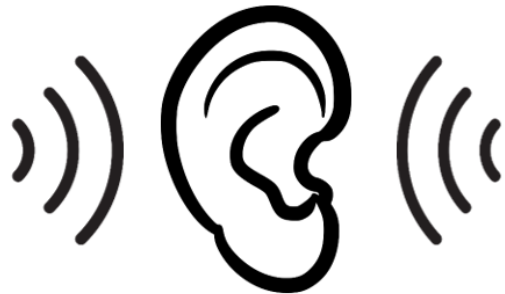

Example: Since **sound** travels slower than light, the thunder is heard after the lightning

Synonyms: noise, music, tone, note

Pitch noun

Definition: how high or low a sound is determined by the rate or frequency of vibrations produced by a sound.

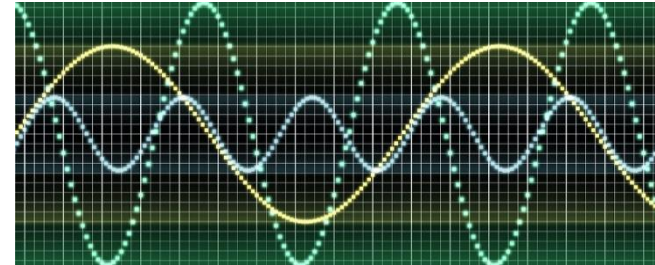

Example: The less vibrating the vocal folds do, the lower **pitch** the voice has.

Volume noun

Definition: how loud or quiet a sound is

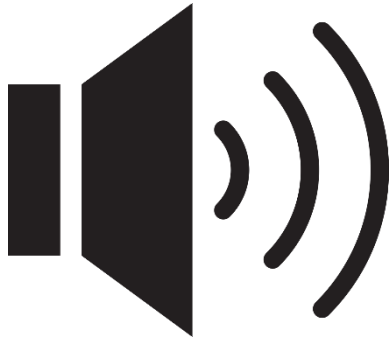

Example: **Volume** is related to the strength, intensity, pressure, or power of the sound.

Synonyms: loudness, amplification

Vibration noun

Definition: to move continuously and rapidly to and fro

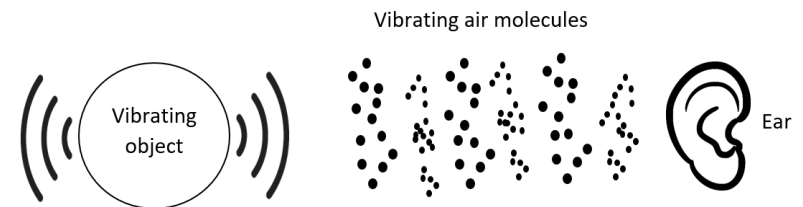

Example: Sound is a type of energy made by **vibrations**.

Word origin: from Latin *vibrat-* 'moved to and fro'

Ear drum noun

Definition: a membrane of the middle ear which vibrates in response to sound waves



Example: When the **eardrum** vibrates, tiny bones within the middle ear transmit the sound signals to the inner ear

Frequency noun

Definition: the rate at which vibrations occur over a particular period of time

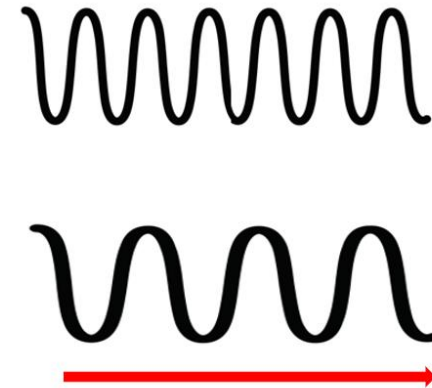

Example: We hear different sounds because of variations in the sound wave **frequency**.

Amplitude noun

Definition: the maximum extent of a vibration

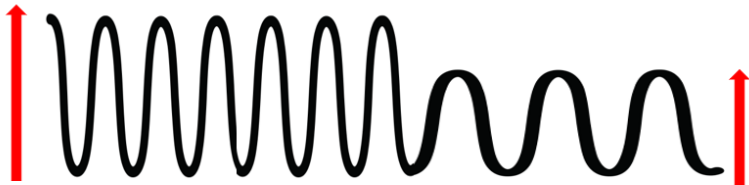

Example: **Amplitude** is the height of the wave. The higher the wave, the louder the sound.

Word origin: from Latin *amplitudo*, meaning 'large, abundant'.

HIAS Science Team

Kevin Neil- County Inspector/Adviser for Science Kevin.neil@hants.gov.uk

Emma Cooper- General Inspector/Adviser for Science emma.cooper3@hants.gov.uk

David Whittle- General Inspector/Adviser for Science david.whittle@hants.gov.uk

For further details on the full range of services available please contact us using the following details:

Tel: 01962 874820 or email: hias.enquiries@hants.gov.uk

Upcoming Courses

Keep up-to-date with our learning opportunities for each subject through our Upcoming Course pages linked below. To browse the full catalogue of learning offers, visit our new Learning Zone. Full details of how to access the site to make a booking are provided [here](#).

- [English](#)
- [Maths](#)
- [Science](#)
- [Geography](#)
- [RE](#)
- [History](#)
- [Leadership](#)
- [Computing](#)
- [Art](#)
- [D&T](#)
- [Assessment](#)
- [Support Staff](#)
- [SEN](#)

Terms and conditions

Terms of licence

Moodle+ subscribers are licenced to access and use this resource and have agreed to pay the annual subscription fee. This authority starts when the fee is paid and ends when the subscription period expired unless it is renewed. This file is for personal or classroom use only. By using it, you agree that you will not copy or reproduce this file except for your own personal, non-commercial use. HIAS have the right to modify the terms of this agreement at any time; the modification will be effective immediately and shall replace all prior agreements.

You are welcome to:

- download this resource
- save this resource on your computer
- print as many copies as you would like to use in your school
- amend this electronic resource so long as you acknowledge its source and do not share as your own work.

You may not:

- claim this resource as your own
- sell or in any way profit from this resource
- store or distribute this resource on any other website or another location where others are able to electronically retrieve it
- email this resource to anyone outside your school or transmit it in any other fashion.